

L1450-35K42

Stem type LED with high output power

L1450-35K42 is an InGaAsP LED mounted on a TO-46 stem with unspherical glass lens being designed for high beam radiant intensity.

On forward bias, it emits a spectral band of radiation, which peaks at 1450nm.

◆ Outer dimension (Unit:mm)

◆ Features

- 1) High radiated intensity
- 2) High Reliability

◆ Specifications

- | | |
|---------------------|------------------------|
| 1) Product Name | NIR LED Lamp |
| 2) Type No. | L1450-35K42 |
| 3) Chip Spec. | |
| (1) Material | InGaAs/InP |
| (2) Peak Wavelength | 1450nm |
| 4) Package | |
| (1) Type | TO-46 stem |
| (2) Lens | Unspherical glass lens |
| (3) Cap | Gold plated |

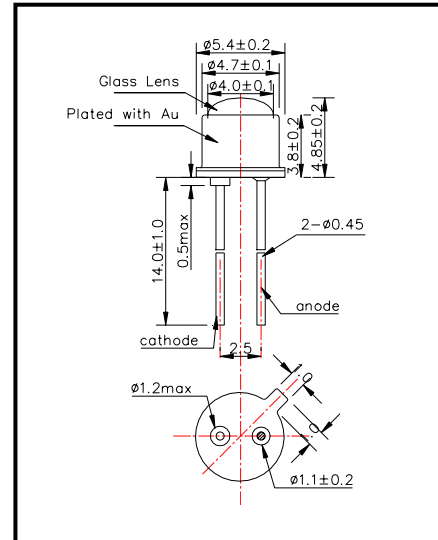

◆ Absolute Maximum Ratings

Item	Symbol	Maximum Rated Value	Unit	Ambient Temperature
Power Dissipation	P _D	130	mW	T _a =25°C
Forward Current	I _F	100	mA	T _a =25°C
Pulse Forward Current	I _{FP}	1000	mA	T _a =25°C
Reverse Voltage	V _R	3	V	T _a =25°C
Operating Temperature	T _{OPR}	-20 ~ +90	°C	
Storage Temperature	T _{STG}	-30 ~ +100	°C	
Soldering Temperature	T _{SOL}	260	°C	

‡Pulse Forward Current condition: Duty=1% and Pulse Width=10us.

‡Soldering condition: Soldering condition must be completed within 3 seconds at 260°C

◆ Electro-Optical Characteristics

Item	Symbol	Condition	Minimum	Typical	Maximum	Unit
Forward Voltage	V _F	I _F =50mA		1.20	1.50	V
Reverse Current	I _R	V _R =5V			10	uA
Total Radiated Power	P _O	I _F =50mA	1.0	2.5		mW
Radiant Intensity	I _E	I _F =50mA		4.0		mW/sr
Peak Wavelength	λ _P	I _F =50mA	1400	1450	1500	nm
Half Width	Δλ	I _F =50mA		100		nm
Viewing Half Angle	θ _{1/2}	I _F =50mA		±6		deg.
Rise Time	t _r	I _F =50mA		10		ns
Fall Time	t _f	I _F =50mA		10		ns

‡Radiated Power is measured by Ando Optical Multi Meter AQ2140 & AQ2742

EPITEX INC. : 4, Nishiaketa-Cho, Higashi-Kujyou, Minami-Ku, Kyoto, Japan

Tel.: ++81-75-682-2338 Fax: ++81-75-682-2267

e-mail: sales-dep@epitex.com

<http://www.epitex.com>